



KITS



PUMPS



METERS



METERED NOZZLES



NOZZLES



WASTE OIL EQUIPMENTS

K600 B/3

FEATURES

- EASY-TO-READ BIG DISPLAY
- SWIVEL DISPLAY
- STANDARD BATTERY
- PULSE-OUT VERSION AVAILABLE
- ADJUSTABLE FLANGES
- AA STANDARD BATTERY

The PIUSI K600 B/3 is an oval gear meter suitable for monitoring the delivery of low, medium and high viscosity oils. This special version includes a large built-in digital display.

PERFORMANCE

UP TO 100 L/MIN	MAX 70 BAR
FLOW RATE	OPERATING PRESSURE
± 0,5 %	0,2%
ACCURACY	REPEATABILITY



K600 B/3

K600 B/3 PULSE-OUT

PACKAGING

CODE	WEIGHT		PACKAGING			
	KG	LBS	MM	INCH	PCS/PALLET	PCS/BOX
METERS						
FO0491010	2	4,4	200X120X140	7,9X4,7X5,5		1
PULSE OUT METER						
FO0492010	2	4,4	200X120X140	7,9X4,7X5,5		1



FILTRATION



FLUID MONITORING



TANK MONITORING



HOSE REELS



ACCESSORIES



MERCHANDISE

INDEX



AIR



ANTIFREEZE



AdBlue®



BIODIESEL



DIESEL



FOOD



GASOLINE



GREASE



KEROSENE



OIL



WATER



WINDSCREEN

CHART

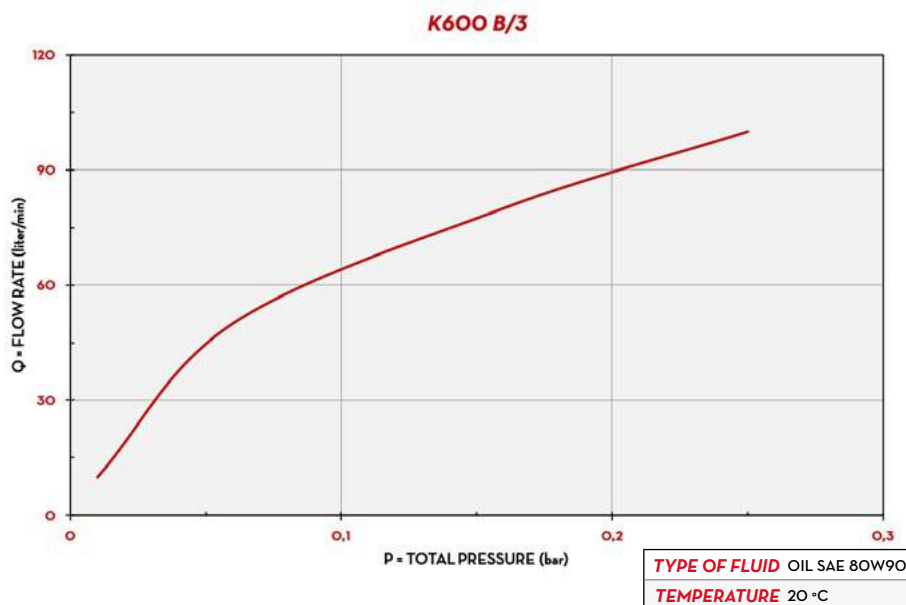

DIMENSIONS

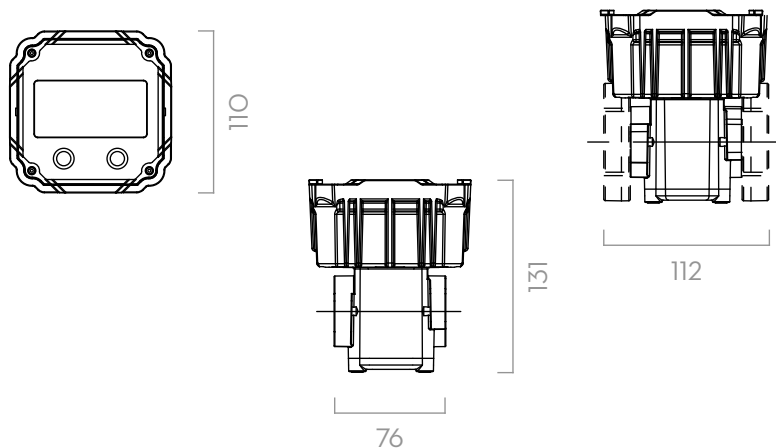

Dimensions expressed in millimeters

IN THE BOX

- K600 B/3 METER
- INSTRUCTION MANUAL

DETAILS



RESET BUTTON



OVAL GEAR



BIG DISPLAY

MATERIALS

- BODY: ALLUMINIUM
- GEARS: TECHNOPYLIMER

TECHNICAL DATA

CODE	DESCRIPTION	FLUIDS TYPE	FLOW RATE		WORKING PRESSURE		BATTERY INCLUDED NO. 2 2X1,5V	FLANGE	INLET OUTLET	INLET FILTER
			L/MIN	GPM	BAR	PSI				
FOO491010	K600 B/3 3/4" BSP OIL		6 - 60	1,58 - 1,58	70	994	YES	YES	3/4" BSP	YES
FOO492010	K600 B/3 3/4" BSP OIL W/PULS OUT		6 - 60	1,58 - 1,58	70	994	YES	YES	3/4" BSP	YES

METERS

PULSE OUT METER

UPON REQUEST AVAILABLE IN NPTF VERSION AND DISPLAY IN GALLON/QUARTER OR PINT

K600 B/3